



# MA26 Meter & MP-T1 Pulser



## Component Technical Manual



Document Ref 903158-001  
Rev - 1  
10/2001

This page is intentionally blank

REVISION RECORD

Date	Revision	Page	Issue	Reason
18/10/2001	1	All	A	Original Issue

This page is intentionally blank

**CONTENTS**

**1. PURPOSE / DESCRIPTION ..... 6**

- 1.1 MA26 Piston Meter ..... 6
  - 1.1.1 Purpose ..... 6
  - 1.1.2 Description ..... 6
  - 1.1.3 Technical Specifications ..... 7
  - 1.1.4 Approvals ..... 7
  - 1.1.5 Dimensions ..... 8
  - 1.1.6 Meter Operation ..... 9
  - 1.1.7 Adjustment ..... 9
- 1.2 MP-T1 Pulser ..... 10
  - 1.2.1 System Description ..... 10
  - 1.2.2 Functional Partition of the MP-T1 electronics ..... 10
- 1.3 MA26 MP-T1 Sealing ..... 13

**2. PARTS LIST ..... 16**

- 2.1 MA 26 Meter ..... 16
- 2.2 MA 26 Collector ..... 18
- 2.3 MA26 Bottom Cover ..... 19
- 2.4 MP-T1 Pulser, Gears and Totaliser ..... 20

**3 TROUBLE SHOOTING ..... 22**

- 3.1 Piston Meter Blocked ..... 22
- 3.2 Calibration Error ..... 23
- 3.3 External Leakage ..... 23

This page is intentionally blank

**CONTENTS**

- 1. PURPOSE / DESCRIPTION ..... 6**
  - 1.1 MA26 Piston Meter ..... 6
    - 1.1.1 Purpose ..... 6
    - 1.1.2 Description ..... 6
    - 1.1.3 Technical specifications ..... 7
    - 1.1.4 Approvals ..... 7
    - 1.1.5 Dimensions ..... 8
    - 1.1.6 Meter operation ..... 9
    - 1.1.7 Adjustment ..... 9
  - 1.2 MP-T1 Pulser ..... 10
    - 1.2.1 System description ..... 10
    - 1.2.2 Functional partition of the MP-T1 electronics ..... 10
  - 1.3 MA26 MP-T1 Sealing ..... 13

## 1 PURPOSE / DESCRIPTION

### 1.1 MA26 Piston Meter

#### 1.1.1 PURPOSE

The MA26 meter has been designed to provide accurate measurement of traditional fuels using a positive displacement system.

#### 1.1.2 DESCRIPTION

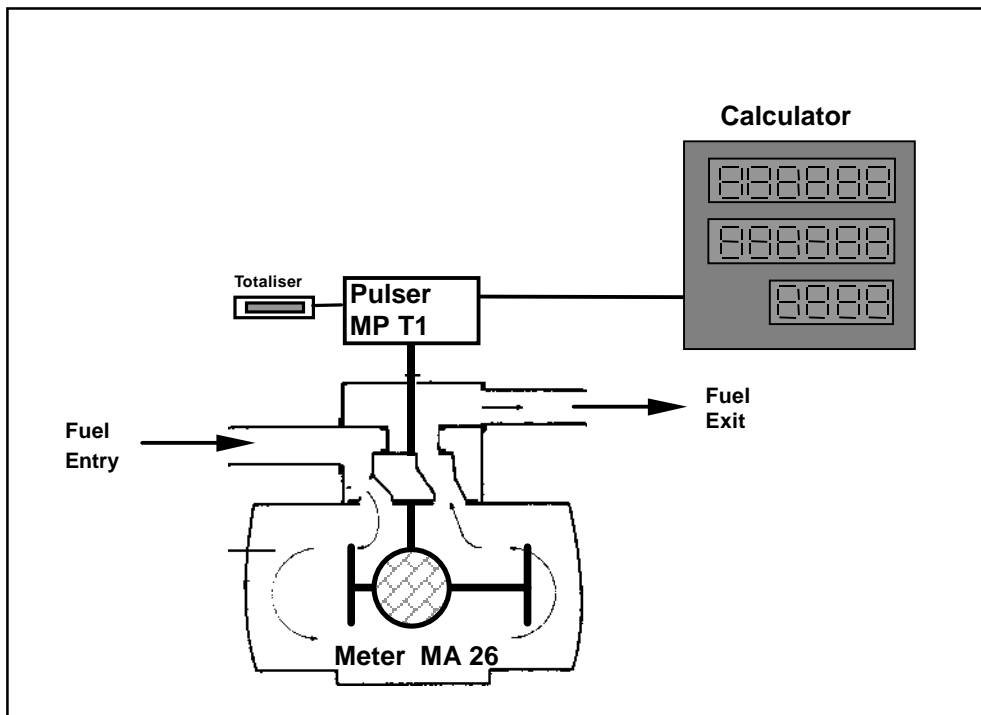

The meter is made up of a body containing four sleeved cylinders which in turn contain four pistons. These pistons move in connection with two transmission rods. Rollers connected to a crankshaft move within the groove of these rods. The alternative linear motion of the pistons therefore results in a rotary crankshaft movement.

A valve is driven by the crankshaft, successively putting the cylinders in communication with the meter inlet and outlet. The valve glides between a slide plate integrated to the body and a gasket fixed to the outlet collector. The slide plate has four holes, which are connected to the four cylinders. The link between the gasket and the outlet collector is made via a Teflon diaphragm, which acts as a seal between intake and exhaust.

The upper section of the crankshaft drives the indicating device.

1.1.3 TECHNICAL SPECIFICATIONS

<b>Characteristics</b>	UNITS	VALUE
Displacement	:	Litre 0.700
Maximum flow-rate	:	l/mn 83
Minimum flow-rate	:	l/mn 5
Accuracy within the flow range	:	% ± 0.3
Maximum service pressure	:	bar 4
Maximum torque during delivery	:	Nm 4
Pressure drop without torque	:	bar 0.08 5 l/mn 0.12 40 l/mn 0.15 50 l/mn 0.26 80 l/mn
Adjusting device operating range	:	% ± 1.1

**Environmental Conditions**

Climate	:	marine, tropical, industrial and polar
Ambient temperature range	:	- 25°C to + 55°C.
Fuel temperature	:	- 25°C to + 55°C.
Atmosphere	:	In accordance with climate.

1.1.4 APPROVALS

**Metrological**

European Approval : 01.00 . 422.003.0 (21 June 2001)

The MA26 meter is a measurement transducer for use in a measuring instrument for liquids other than water. As such it is tested and certified according to the OIML (Organisation International de Metrology Legal) Recommendation R117. The certificate is issued under number R117(1995)-NL-01.04 by the NMI (Dutch national test institute).

**Safety**

The MA26 meter with the MP-T1 pulser is constructed for use in gasoline dispensers in a zone 1 area. Therefore the pulser, as an electrical part, has been approved by LCIE according the European Standard EN 50014 and EN 50018 with protection code EExdIIBT6 with certificate number DEMKO 00.E.128709X.

1.1.5 DIMENSIONS

Weight : 7 Kg

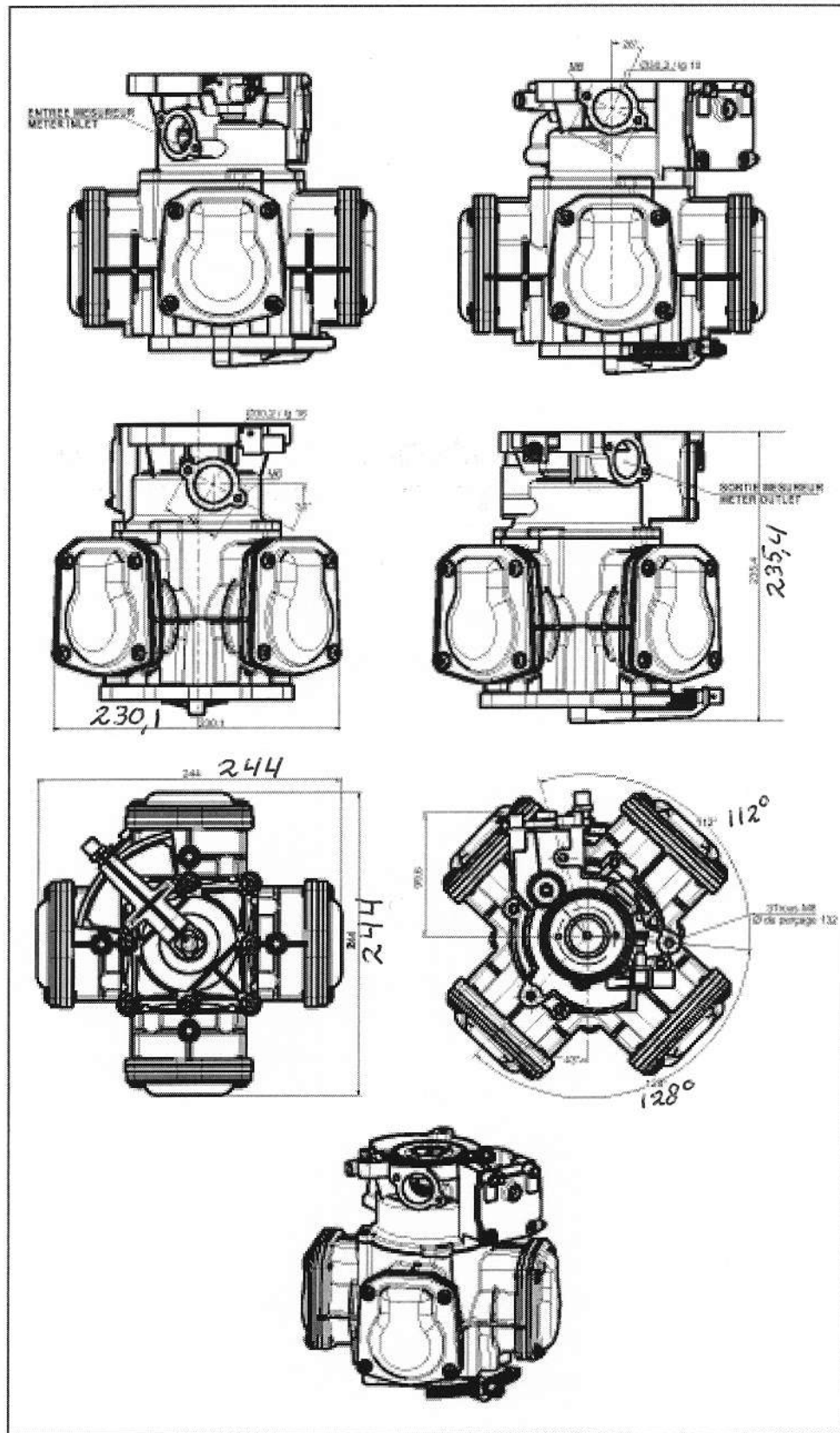

1.1.6 METER OPERATION

The fuel enters the meter via the intake orifice (5) and flows up to the valve (3), where it applies pressure to the piston (7), while the piston (6) linked to the former by the connecting rod (8) is in communication with the exhaust orifice via the opening (4) of the rotary valve (3). Both perpendicular pistons that are linked to the connecting rod (9) operate under the same conditions, offset by 90°.

Inside the connecting rods (8 and 9), two rolls (10) are mounted on the crankshaft (2). The upper crankshaft pin drives the distribution valve (3) through a peg (1) located on the crankshaft, transmitting the rotary movement to the indicating device.

1.1.7 ADJUSTMENT

Capacity can be adjusted by varying the piston stroke. The device contains a central cam (13) with four ramps, each one acting successively on the four pistons. Travel can be adjusted by using a lever (11) to turn the cam around its axle (12). The lever may be positioned firstly in relation to the position of the cam, via a square section part (14). Its position on the notched part (15) may be adjusted using the screw (16) which acts as a positioning pin.

The lever is designed in such a way that, whatever its position on the notched part, the screw (16) is always hidden. It is protected by the sealing device (17).

The clearance needed for adjustment is obtained by the clearance between the rollers and the connecting rod sliders.

Each notch on the notched part modifies the meter's cylinder capacity by 0.1%

Access to the adjusting device is made impossible by a seal.

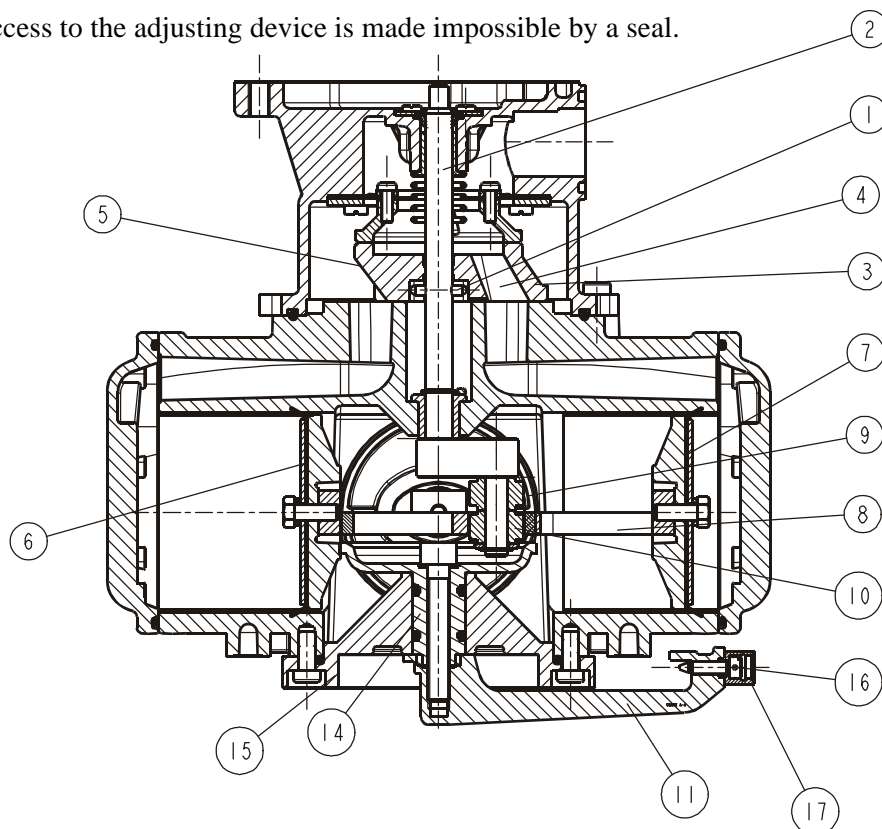

1.2 MP-T1 Pulser

1.2.1 SYSTEM DESCRIPTION

The MP-T1 pulser is part of the measurement transducer used in a fuel dispenser. The task of this unit is to detect and to indicate when a volume of 1cl fuel has left this unit. Below is a short description of the different parts of the measurement transducer.

This device will be placed in series with the nozzle of a dispenser. It converts the fuel flow into rotations of a shaft. One rotation of the MA26 volume meter represents a fuel flow of 70cl.

The MP-T1 housing is placed on top of the volume meter. This housing contains the MP-T1 electronics (placed on a support), 3 gear wheels and a magnetic disc. The rotation of the volume meter shaft will be conveyed by the 3 gear wheels to the magnetic disc. The speed ratio volume meter shaft:magnetic disc = 1:3.5.

So one turn of the disc represents 20 cl.

The electronic outputs of the MP-T1 pulser, which contain “cl” pulses, will drive the inputs of the calculator.

One or more pulsers, each with a 4 wire link, are connected to the calculator. This link contains two pulse lines and two power lines to supply the pulser

1.2.2 FUNCTIONAL PARTITION OF THE MP-T1 ELECTRONICS

The MP-T1 electronics take care of the translation of the magnetic field changes into proper “cl” pulses needed for the calculator. The MP-T1 electronics can be divided into the following functional blocks. The functions of the different blocks are described on the following pages. All digital functions of the MP-T1 electronics are integrated in an Asic.

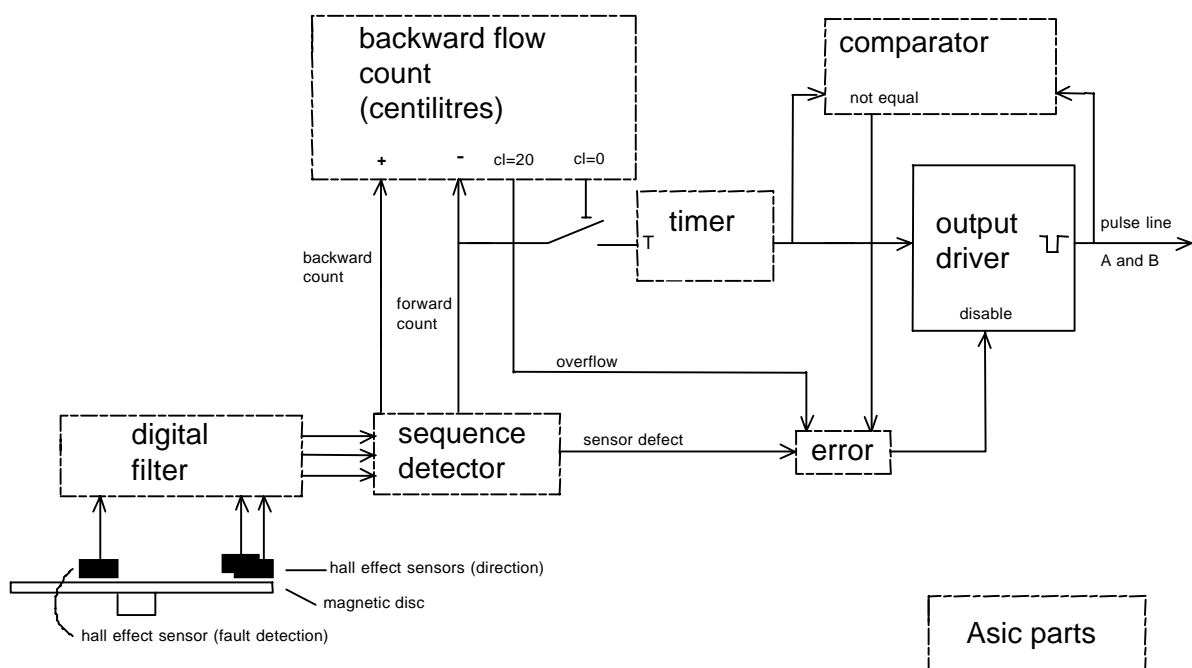

Issue A

### **Magnetic disk**

The disc contains one outer ring, divided into 20 north and 20 south polarised magnetic parts and one inner ring divided into 10 north and 10 south polarised magnetic parts. The disc will be driven by, as mentioned before, the volume meter. A liquid flow in forward direction (this liquid has left the measurement transducer) results in a counter-clockwise movement of the disc. If the liquid is going backwards the disc will rotate clockwise.

The disc can have small movements in both directions, this will be caused by vibrations of the MP-T1 pulser. These movements are called “oscillations of the disc”. The oscillations will never result in centilitre pulses on the output of the MP-T1 pulser.

### **Hall effect sensors (direction)**

Two sensors (sensor A and sensor B) are placed above the outer ring of the disc. They are used to indicate the direction of the disc. Every transition on the signal coming from sensor B represents a half centilitre.

### **Hall effect sensor (fault detection)**

A third sensor (sensor C) is placed above the inner ring of the disc. Due to the fact that this ring contains 10 north and 10 south polarised magnetic parts, the output frequency of this sensor will be the half of the frequency coming from the two other sensors. This difference in frequency makes it possible to distinguish between normal operation, sensor defects or disc oscillations.

### **Digital filter**

This part will remove glitches shorter than  $8\mu\text{s}$  from the sensor signals.

### **Sequence detector**

The sequence detector distinguishes the different movements of the disc by evaluating the three sensor signals.

### **Backward flow count (centilitres)**

When the disc turns clockwise the sequence detector generates backward count pulses. The backward flow count buffer keeps up with the amount of backwards count pulses. When the buffer reaches 20 cl (40 pulses) it will generate an overflow message. If the disc turns counter-clockwise the sequence detector generates forward count pulses. The backward flow count buffer will decrease with the amount of forward count pulses until it reaches the 0 cl. At this point the buffer will not decrease anymore and the switch will be closed so that the timer receives forward count pulses on its trigger input.

### **Timer (400 $\mu\text{s}$ )**

A pulse on the trigger input of the timer will start this one shot 400 $\mu\text{s}$  timer. During this 400 $\mu\text{s}$ , the timer will activate the output driver for line A (or B). Every half cl the timer alternates between line A and B. So, if there was a pulse on output line A, a half cl later it will be followed by a pulse on output line B. A pulse on output line B will be followed by a pulse on output line A, etc.

**Output driver**

The output driver is necessary to supply the current needed for the inputs of the calculator. Furthermore it delays the low to high transition of the cl pulses on the output lines A and B. This delay is to prevent cross talk between the two pulse lines and interference on other lines.

**Comparator**

This block checks the input and output of the output driver during the 400 $\mu$ s pulse. If the output line is high (idle state) while the input of the driver is activated, it will send a “not equal” signal to the error block.

The inputs of the comparator used for monitoring lines A and B are provided with a digital filter. This filter will remove glitches (smaller than 32 $\mu$ s) from these two signals.

**Error**

The signals “overflow”, “sensor defect” and “not equal” are collected here. When one or more signals are active, the error signal will be activated. This signal can only be deactivated by switching off the MP T1 power. When the error signal is activated, the output driver is disabled, so the output lines become low (error indication of the MP-T1).

### 1.3 MA26 MP-T1 Sealing

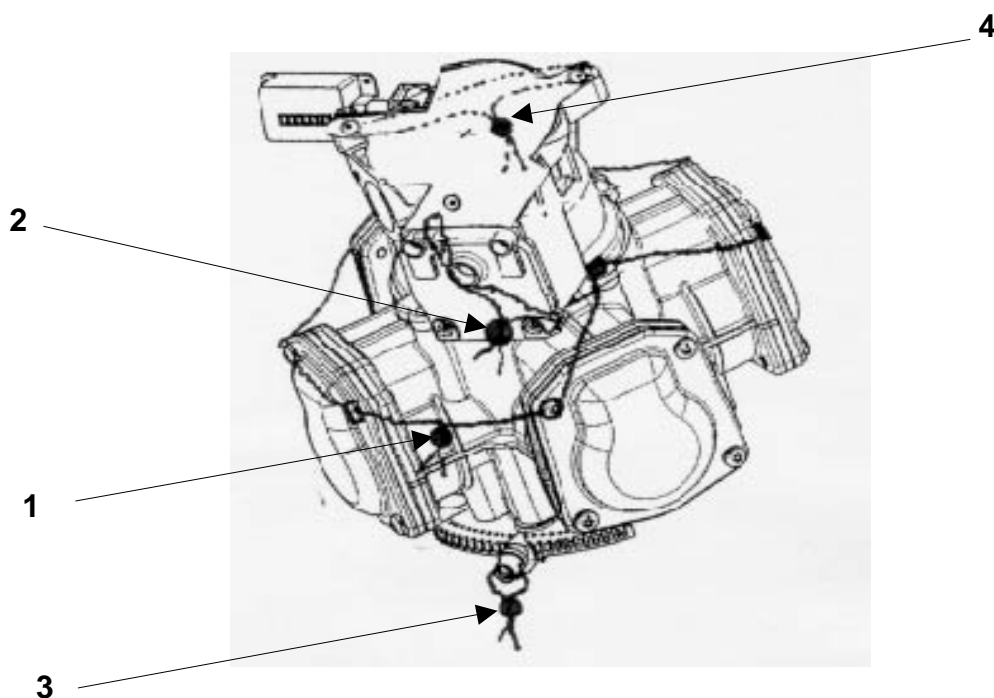

#### **Piston sealing**

A sealing wire feeds through the head of a seal screw fitted in each piston end cover. This seal wire also diverts upwards between two of the end covers to feed through a seal screw securing the top housing to the meter body.

The seal wire is drawn taught and a seal fixed for stamp access above the calibration quadrant.

#### **Pulser sealing**

A sealing wire feeds through holes in the bottom right hand corner of the pulser casting and meter housing, then travels diagonally across the front of the pulser to pass through either a hole in the meter mounting plate or the head of the front meter mounting screw.

The seal wire is drawn taught and a seal fixed for stamp access in front of the pulser.

#### **Calibration sealing**

A seal wire passes through holes in the calibration locking screw and is drawn taught and a seal fixed.

#### **Meter sealing**

The meter is sealed into the dispenser by passing a seal wire through the heads of two of the meter mounting screws.

The seal wire is drawn taught and a seal fixed for stamp access on the top of the hydraulic stack.

This page is intentionally blank

**CONTENTS**

**2. PARTS LIST ..... 16**

2.1 MA 26 Meter ..... 16

2.2 MA 26 Collector ..... 18

2.3 MA26 Bottom Cover ..... 19

2.4 MP-T1 Pulser, Gears and Totaliser ..... 20

2. PARTS LIST

2.1 MA 26 Meter

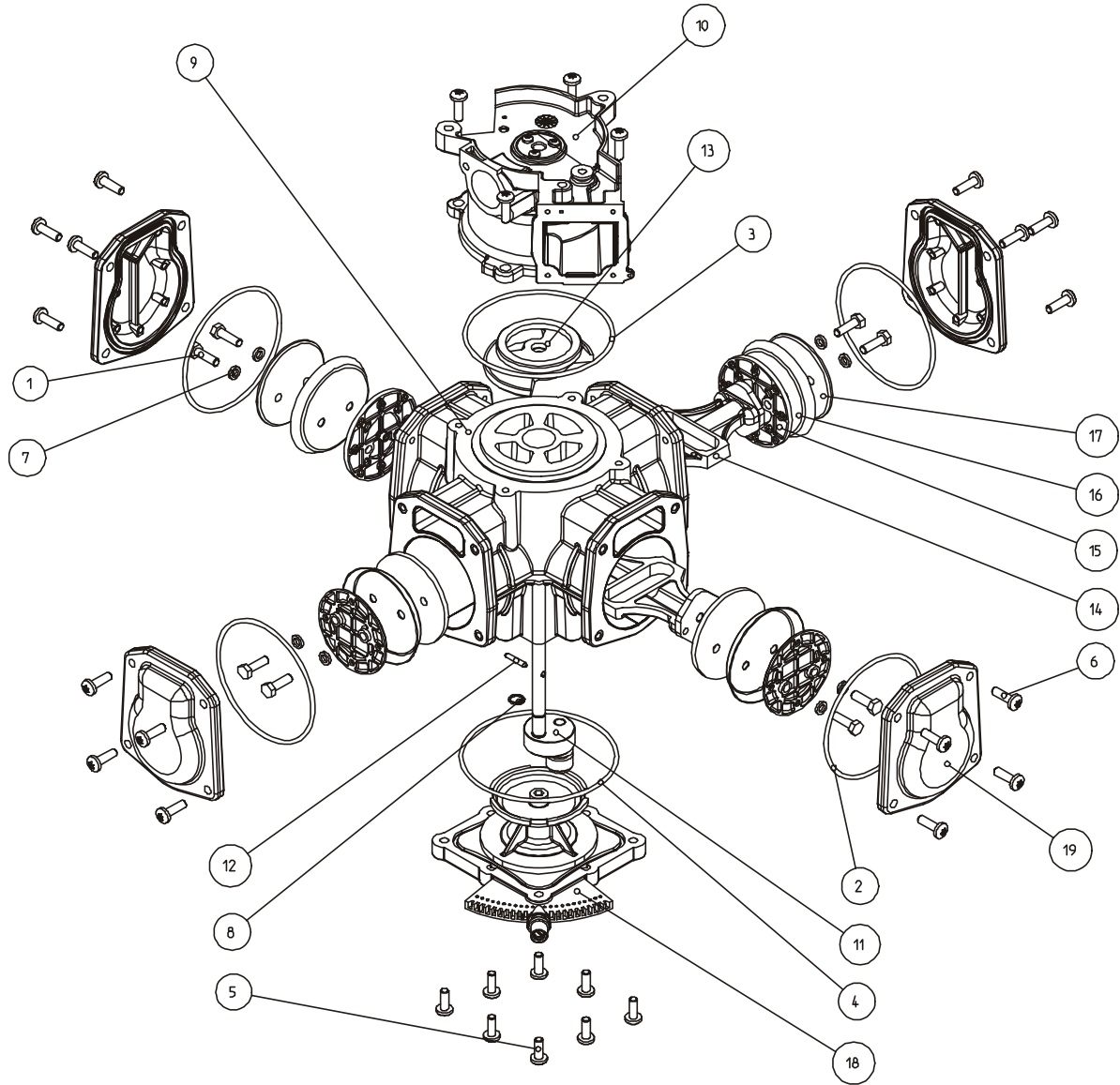

Item	Reference	Désignation	Description
	901106	Mesureur MA 26 assemblé	MA26 meter assembly
1	900015-010	Vis M6-20	Screw M6-20
2	900050-009	Joint torique 94,5 x 3	O-ring 94,5 x 3
3	900050-010	Joint torique 104,2 x 3	O-ring 104,2 x 3
4	900050-011	Joint torique 110 x 3	O-ring 110 x 3
5	900053-002	Vis torx M6-16	Torx screw M6-16
6	900053-003	Vis torx M6-20	Torx screw M6-20
7	900101-004	Joint plat	Flat seal
8	900103-002	Circlips	Circlips
9	901240	Corps équipé	Equipped body
10	901246	Collecteur assemblé	Collector assembly
11	901260	Vilebrequin	Crankshaft
	901264	Galet	Roll
	900008-005	Rondelle laiton	Brass washer
	900047-001	Anneau truarc	Truarc ring
12	901265	Doigt d'entraînement	Drive stud
13	901266	Tiroir	Rotary valve
14	901267	Coulisseau	Rod
15	901268	Plateau interne	Piston disk
16	901269	Manchette	Piston seal
17	901270	Plateau externe	Tightening disk
18	901271	Embase assemblée	Bottom cover assembly
19	901277	Couvercle	Cover

2.2 MA 26 Collector

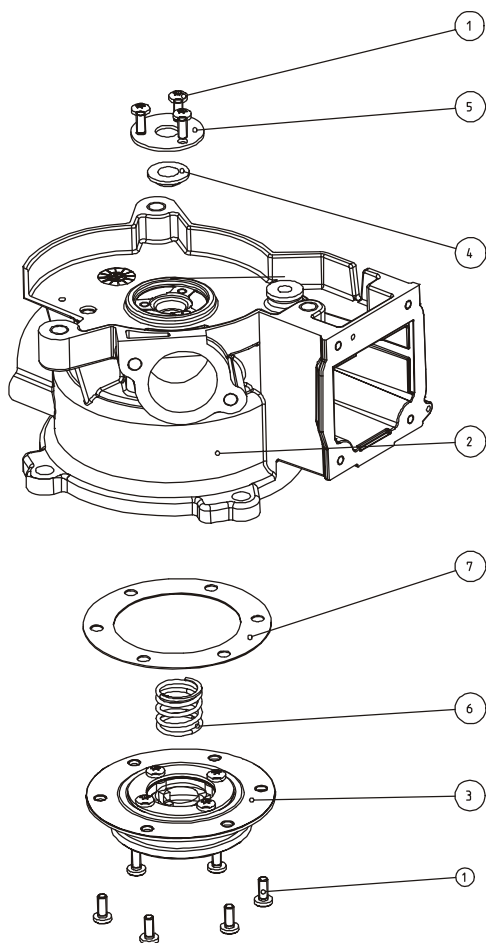

Item	Reference	Désignation	Description
1	900053-001	Vis torx M4-10	Torx screw M4-10
2	901247	Collecteur bagué	Collector with bearing
3	901249	Supp. membrane assemblé (rodé)	Countervalve assembly (lapped)
4	901251	Joint profil S vert	Lipseal (green viton)
5	901252	Rondelle laiton	Brass washer
6	901256	Ressort	Spring
7	901257	Joint plat	Flat seal

2.3 MA26 Bottom Cover

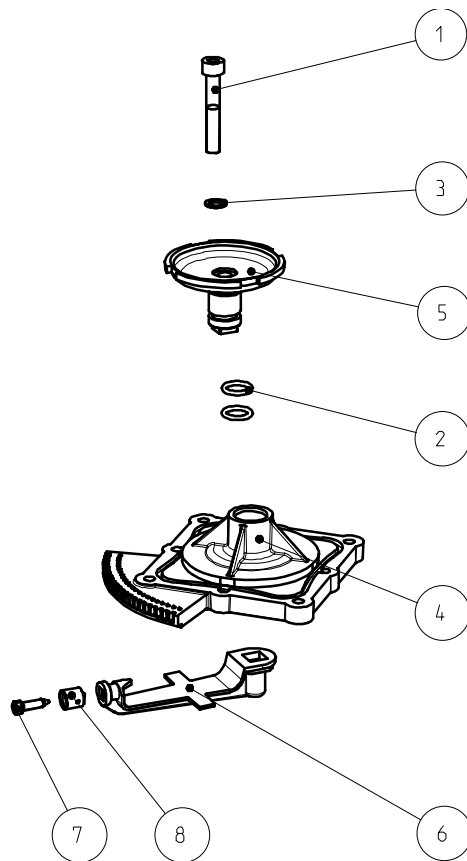

Item	Reference	Désignation	Description
1	900017-004	Vis CHc M8-50 inox	CHc stainless steel screw M8-50
2	900050-003	Joint torique 13,6 x 2,7	O-ring 13.6 x 2.7
3	900101-005	Joint plat	Flat seal
4	901272	Embase	Bottom cover
5	901273	Came	Adjustment cam
6	901274	Levier de réglage	Adjustment lever
7	901275	Vis de plombage	Sealing screw
8	901276	Cage de plombage	Seal housing

2.4 MP-T1 Pulser, Gears and Totaliser

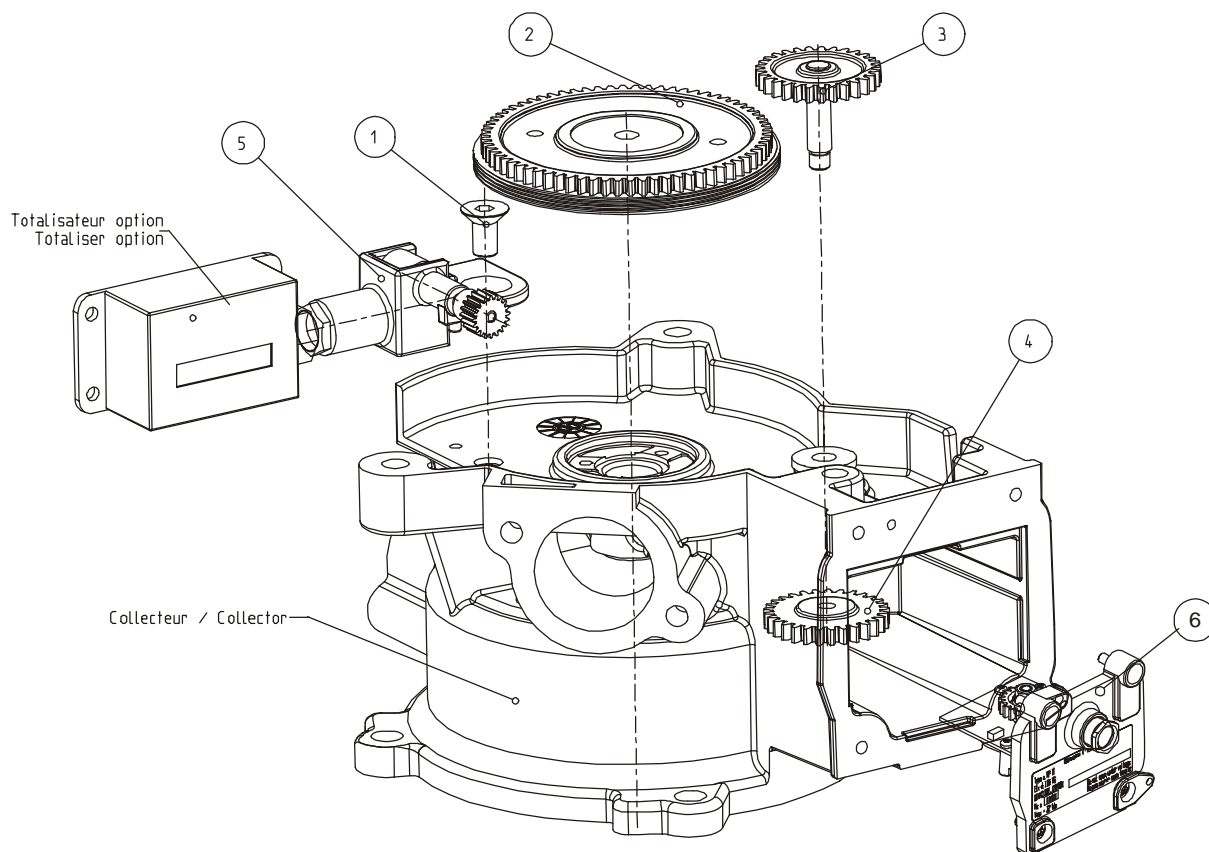

Item	Reference	Désignation	Description
1	900643-001	Vis Fhc M6 x 12 inox	Screw M6-12 stainless steel
2	901280	Pignon - vis d'entraînement	Endless screw wheel
3	901281	Pignon axe intermédiaire	Intermediate shaft gear
4	901283	Pignon entraîneur émetteur	Pulser drive wheel
5	901284	Support totalisateur équipé	Totaliser support assembly
6	900843	Emetteur MP T1 avec câble	MP-T1 pulser with cable
	900743-002	Totalisateur mecanique	Mechanical Totaliser
	900043-001	Ecrou serrures pour totalisateur	Locking nut for totaliser M10x1.00

**CONTENTS**

**3 TROUBLE SHOOTING ..... 22**  
3.1 Piston Meter Blocked ..... 22  
3.2 Calibration Error ..... 23  
3.3 External Leakage ..... 23

Issue A

3 TROUBLE SHOOTING

3.1 Piston Meter Blocked

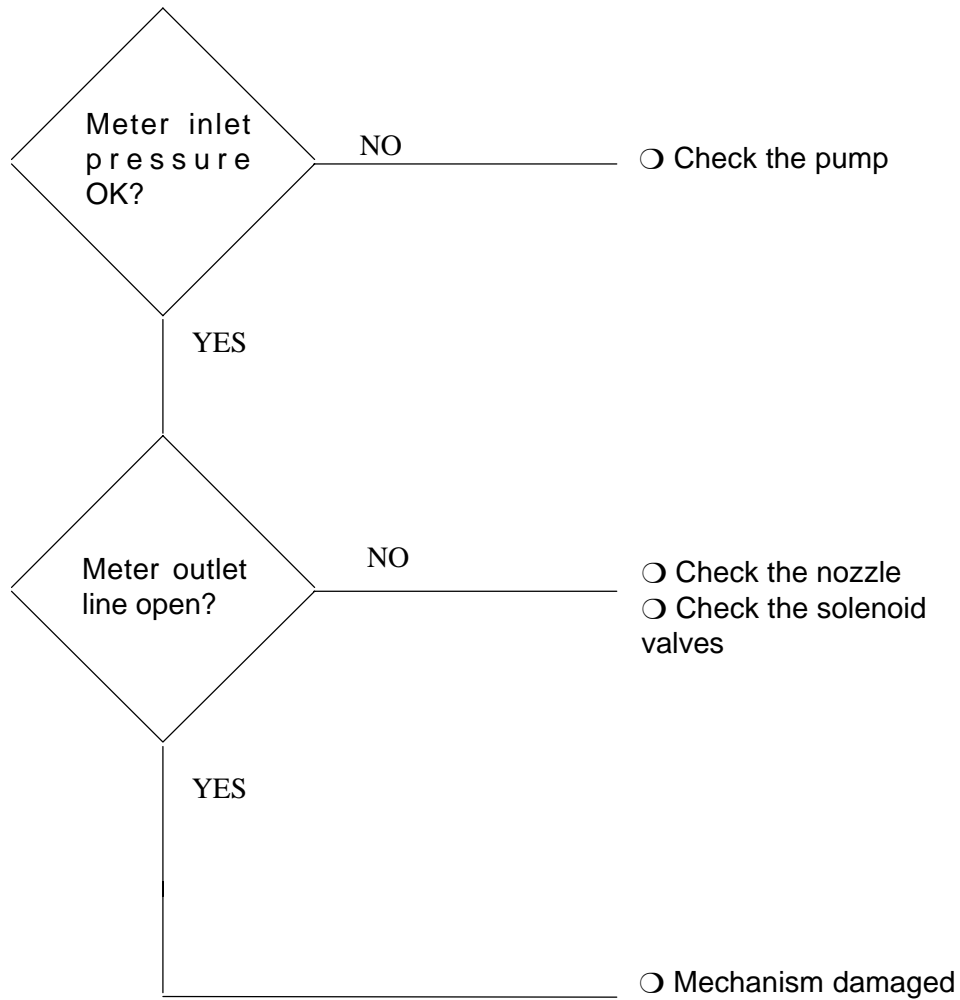

3.2 Calibration error

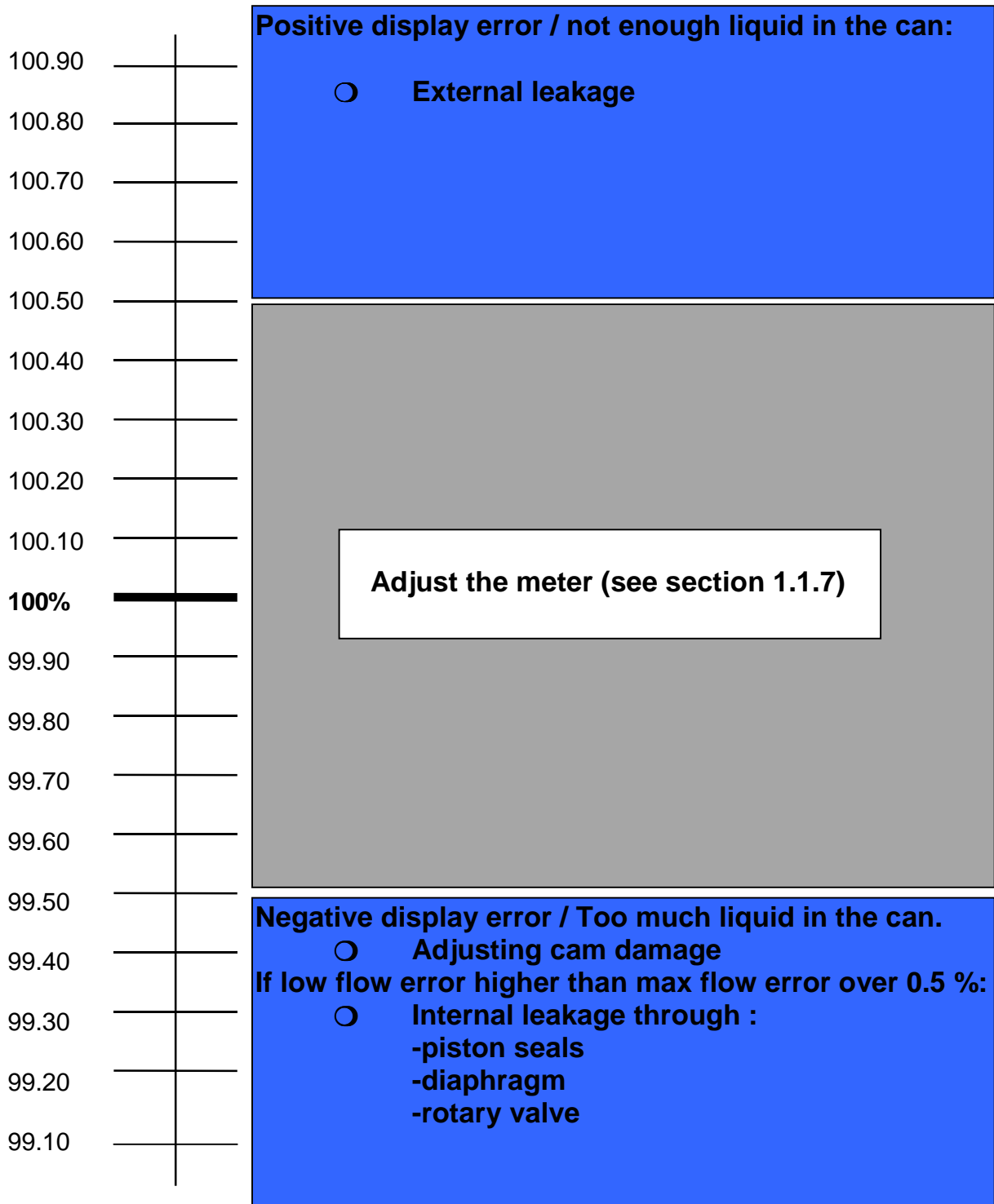

3.3 External Leakage

- Leakage :
- ...through the drive shaft: lip seal faulty
  - ...under the collector : collector O-ring faulty
  - ...under a cover: cover O-ring faulty
  - ...through the adjustment axle: adjustment axle O-ring faulty
  - ...under the bottom cover : bottom cover O-ring faulty

Issue A

This page is intentionally blank

This page is intentionally blank



- F Tokheim Europe & Africa Headquarters** **GB Manufacturing**  
ZAC Paris Nord 2  
B.P. 40027 Tremblay-en-France  
95912 Roissy C.D.G. Cedex  
France  
☎ +33 (0)1 49 90 77 00  
☎ +33 (0)1 49 90 77 77  
✉ marcom@tremblay.tokheim.com
- Unit 3, Baker Road  
West Pitkerro Industrial Estate  
Dundee DD5 3RT  
Scotland  
☎ +44 (0)1382 598000  
☎ +44 (0)1382 598001  
✉ service@tokheimuk.com

## SALES & SERVICE DIVISIONS - EUROPE

- A Austria**  
Tokheim  
Eitzenberger Straße 4-6  
A-2544 Leobersdorf  
☎ +43 (0) 2256 606 0  
☎ +43 (0) 2256 606 170  
✉ office@leobersdorf.tokheim.com
- B Belgium**  
Tokheim  
Everdongenlaan 31  
2300 Turnhout  
☎ +32 (0) 14 44 85 00  
☎ +32 (0) 14 44 85 55  
✉ saelen@turnhout.tokheim.com
- CZ Czech Republic**  
Tokheim  
Pernerova 48  
CZ-18602 Prague 8  
☎ +420 2 248 90312  
☎ +420 2 232 72 67  
✉ pribrsky@prague.tokheim.com
- DK Denmark & Scandinavia**  
Tokheim Scandinavia  
Hejrevang 10  
3450 Allerød  
☎ +45 48 13 45 45  
☎ +45 48 17 45 96  
✉ service@alleroed.tokheim.com
- F France**  
Tokheim Services France  
9 Avenue Galilée  
92350 Le Plessis-Robinson  
☎ +33 (0)1 41 36 13 00  
☎ +33 (0)1 41 36 13 70  
✉ parise@plessis.tokheim.com
- F Tokheim Sofitam Applications**  
ZAC Paris Nord 2  
B.P. 40027 Tremblay-en-France  
95912 Roissy C.D.G. Cedex  
☎ +33 (0)1 49 90 77 00  
☎ +33 (0)1 49 90 77 77  
✉ accueil-tremblay@tremblay.tokheim.com
- D Germany**  
Tokheim GmbH  
Lothstrasse 1a  
D-80335 München  
☎ +49 (0) 89 189 530  
☎ +49 (0) 89 189 533 99  
✉ service@muenchen.tokheim.com
- I Italy**  
Tokheim Sofitam Italia S.r.l.  
S.P. 26 Km 10 800  
14030 Scuzolengo (AT)  
☎ +39 0141 2038200  
☎ +39 0141 2038222  
✉ info@asti.tokheim.com

- NL Netherlands**  
Tokheim Netherlands B.V.  
Touwslagerstraat 17  
Postbus 4186  
2980 GD Ridderkerk  
☎ +31(0) 180 48 15 00  
☎ +31(0) 180 48 15 55  
✉ sales@ridderkerk.tokheim.com

- PL Poland**  
Pol-Germann Tokheim Sp. z o.o.  
UL. Narwicka 1  
PL-80-557 Gdansk  
☎ +48 58 343 21 71  
☎ +48 58 343 22 15  
✉ plgerma@softel.gda.pl

- P Portugal**  
G.N.C.  
Parque de Ciencia e Tecnologia  
Edificio Tecnologia 1, N° 27  
2780-920 Oeiras  
Lisboa  
☎ +351 214 220 420  
☎ +351 214 214 226

- RUS Russia**  
Tokheim Russia & CIS  
50, Office 603-605, Zemlyanoy Val St.  
Moscow, 109544 GSP  
☎ +7 095 916 6879  
☎ +7 095 916 6878  
✉ kolobov@dol.ru

- SK Slovak Republic**  
Tokheim  
Mlynske Nivy 70  
SK-82015 Bratislava  
☎ +421 2 58 27 02 15  
☎ +421 2 52 41 41 23  
✉ schroeder@berlin.tokheim.com

- E Spain**  
Koppens Iberica  
Calle Imprenta 5  
Poligono Industrial de Alcobendas  
28100 Alcobendas (Madrid)  
☎ +34 91 661 28 13  
☎ +34 91 661 41 30  
✉ urra@madrid.tokheim.com

- CH Switzerland**  
Tokheim  
Route du Crochet 7  
Case Postale 50  
1762 Givisiez  
☎ +41 (0)26 460 51 11  
☎ +41 (0)26 460 51 12  
✉ user@givisiez.tokheim.com

- GB United Kingdom**  
Tokheim  
Adur Boatyard, Old Shoreham Road  
Shoreham-By-Sea  
West Sussex BN43 5TA  
☎ +44 (0)1273 454831  
☎ +44 (0)1273 464863  
✉ sales@tokheimuk.com

## AFRICA

- F Export Division**  
ZAC Paris Nord 2  
B.P. 40027 Tremblay-en-France  
95912 Roissy C.D.G. Cedex  
France  
☎ +33 (0)1 49 90 77 56  
☎ +33 (0)1 49 90 77 93  
✉ marcom@tremblay.tokheim.com

- RFC Cameroon**  
Socatam S.A.  
BP 3941  
Douala  
☎ +237 40 57 86  
☎ +237 40 57 88  
✉ socatam.douala@camnet.cm

- MA Morocco**  
Matam S.A.  
209 Bld Moulay Ismail  
Route de Rabat  
Casablanca  
☎ +212 22 40 40 24  
☎ +212 22 40 40 21  
✉ matam@wanadoo.net.ma

- SN Senegal**  
Cosetam S.A.  
Quartier de Bel Air  
Route des Hydrocarbures  
BP 1237  
Dakar  
☎ +221 832 23 71  
☎ +221 832 68 34  
✉ cosetam@ns.arc.sn

- ZA South Africa**  
Tokheim South Africa Ltd  
Stand 110, Precision Road  
Kya Sand, Randburg  
☎ +27 11 462 2105  
☎ +27 11 462 1942  
✉ tokheimsales@tokheim.co.za

- TN Tunisia**  
Cottam SARL  
116 Ave de l'Union du Maghreb Arabe  
BP 117  
La Soukra  
2036 Tunis  
☎ +216 175 95 50  
☎ +216 175 95 30  
✉ cottam@planet.tn

*As Tokheim regularly improves its products to ever better respond to evolving market and regulatory requirements, it reserves the right to change any of the specifications of these products, and this without prior notice.*